

# Modular Roller Conveyor System

## Building blocks to satisfy your needs - Modular Roller Conveyor

For packages as small as 250mm in length.

Handles packages up to 30kg (or 50kg Eurototes).

Speeds up to 114m/min.



### Transport Straight

Transport Straights are the basic building blocks of any modular conveyor system. Designed to link to all other modules and enable bolt-in accessories, such as Transfers and ZLP zones, to be fitted without any rework. Each Module's pre-fitted and tested motor provides efficient drive to the rollers via a durable flat belt.

- Modules up to 6 metres in length
- Speeds up to 114m/min
- 83mm and 125mm roller pitch



### Transport Curve

Modular Roller Curves come pre-fitted with a unique round belt tangential drive system, which guarantees the belt runs truly perpendicular to the tapered roller axes. This provides an efficient, low wearing drive mechanism. As a result, long service life and low maintenance costs are achieved.

- 30, 45, 60 and 90 degree curves.
- Unique long-life tangential drive belt design
- Quick change drive belt



### Personnel Gate

The personnel gate utilises a very simple and effective drive wheel system which picks up drive from the adjacent module. Drive is lost when the gate is lifted, and the safe pop out roller feature is maintained by a locking device which prevents the rollers from dropping out. Gas struts give assistance during lifting and closing of the gate.

- Available in 1000mm modules for 805mm clear entry
- Left and Right handed units available

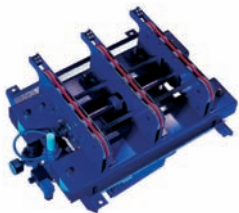

### Transfer

A simple to install self contained unit that can be fitted at any point into a transport straight (in 83mm pitches) to divert packages from, or bring packages onto, a main line. The transfer is fitted with only four bolts, directly to standard pre-punched holes. Powerful pneumatic airbags lift the transfer on a stable structure.

- Transfer speeds up to 83m/min as standard
- Complete with integral pneumatic controls and air pressure regulation
- Bi-directional



### Blade Stop

The blade stop is used to hold back a queue of boxes and accumulate them. We have designed a speed up roller system that provides a localised speed increase for packages exiting the Blade Stop, enabling a gap to be generated between multiple packages.

- Can be installed at any point on a conveyor
- Fast pneumatic operation

Conveyor Widths from 300mm to 800mm.

Left and right hand drive systems.

Adjustable line pressure fitted as standard.

No cable trunking required.

Fully CE compliant.



### Wallaby

The unique Wallaby design has been added to the Modular Conveyor range from our successful lineshaft system. Used as either single units to perform the function of lane diverters or coupled to other units to form a multi-lane sorter. It is highly suited to the modular concept, so much so that we have been able to increase its speed range (for line and divert rollers). Shorter module lengths give higher discharge lane density in sortation areas, and achieve greater space utilisation.

- Unique raised tooth divert chain operates to exact package lengths
- Throughputs of up to 8,000 packages per hour
- A very cost effective sortation system when used with Cell Controllers
- Right and left hand 30 degree modules available
- Divert speeds up to 118m/min



### Accumaflow

The unique and highly successful "accumaflow" principle has been applied to the Modular Range of conveyors. This conveyor provides good positive drive yet offers very low pressure as loads accumulate. It features adjustable line pressure and the same efficient and durable flat belt drive system used on transport straights.

- Modules up to 6m in length
- Rollers designed to reduce overall line pressure
- 83mm roller pitch

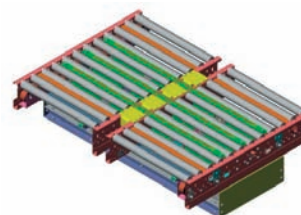

### Double Transfer

A conveyor module complete with a double transfer unit. The modules are available to suit the standard conveyor widths when there is a 70mm gap between the conveyors.

- Transfer speeds up to 83m/min as standard.
- Bi-directional when controlled via a reversing motor junction box.
- 83mm roller pitch
- Pneumatic operation
- Pre-fitted with 24vdc pneumatic solenoid valve.
- Up to 30 transfers/minute

### Further Modules and Accessories

Other modules currently available include the Merging Spur and Corner Turn.

Our commitment to the modular design has resulted in a large investment in this project.

As a result we will be continually adding modules to our existing range.

Please contact us for details..

**A full range of accessories is available including:**

- Facia
- Guides
- Photo Electric Cells
- Stands
- Underguards

## Modular Roller Conveyor System



Transport Straights are the building blocks of any modular conveyor system. Designed to link to all other modules and enable bolt-in accessories, such as Transfers and Zero Line Pressure (ZLP) zones, to be fitted without any rework. Each Module's pre-fitted and tested motor provides efficient drive to the rollers via a durable flat belt.

- **Modules up to 6 metres in length**
- **Speeds up to 114m/min**
- **83mm and 125mm roller pitch**
- **Precision bearings used throughout**
- **Low noise >65 dBa**

# Modular Roller Conveyor System

## Conveyed Loads

Loads must be dry with a smooth base, cardboard on plastic being ideal.

Max product load no greater than 10 kg. per roller.

Max product weight of any single carton is 30 kg.

## Line Pressure

Line pressure is adjustable by repositioning the pressure wheels via the cam adjusters.

## Environment

To be used indoors in a dry environment only between 5°C and 40°C ambient temperature.

## Electrical Power

Motors should be connected to 415V 3-phase, 50Hz supply. Each transport straight is supplied pre-fitted with an electrical junction box providing a quick plug and socket connection to the motor.

Conveyor Speed (m/min)	Module Length (m)	Motor Power (kW)	Running Current (A)
9.8	up to 3	0.09	0.45
9.8	>3 to 6	0.18	0.85
14.0	up to 3	0.09	0.45
14.0	>3 to 6	0.18	0.85
19.0	up to 3	0.09	0.45
19.0	>3 to 6	0.18	0.85
22.0	up to 3	0.09	0.45
22.0	>3 to 6	0.18	0.85
27.0	up to 3	0.09	0.45
27.0	>3 to 6	0.18	0.85
37.0	up to 3	0.09	0.45
37.0	>3 to 6	0.18	0.85
45.6	up to 3	0.15	0.48
45.6	>3 to 6	0.27	0.76
57.0	up to 3	0.15	0.48
57.0	>3 to 6	0.27	0.76
76.0	up to 3	0.15	0.48
76.0	>3 to 6	0.27	0.76
114.0	up to 3	0.18	0.85
114.0	>3 to 6	0.27	0.76

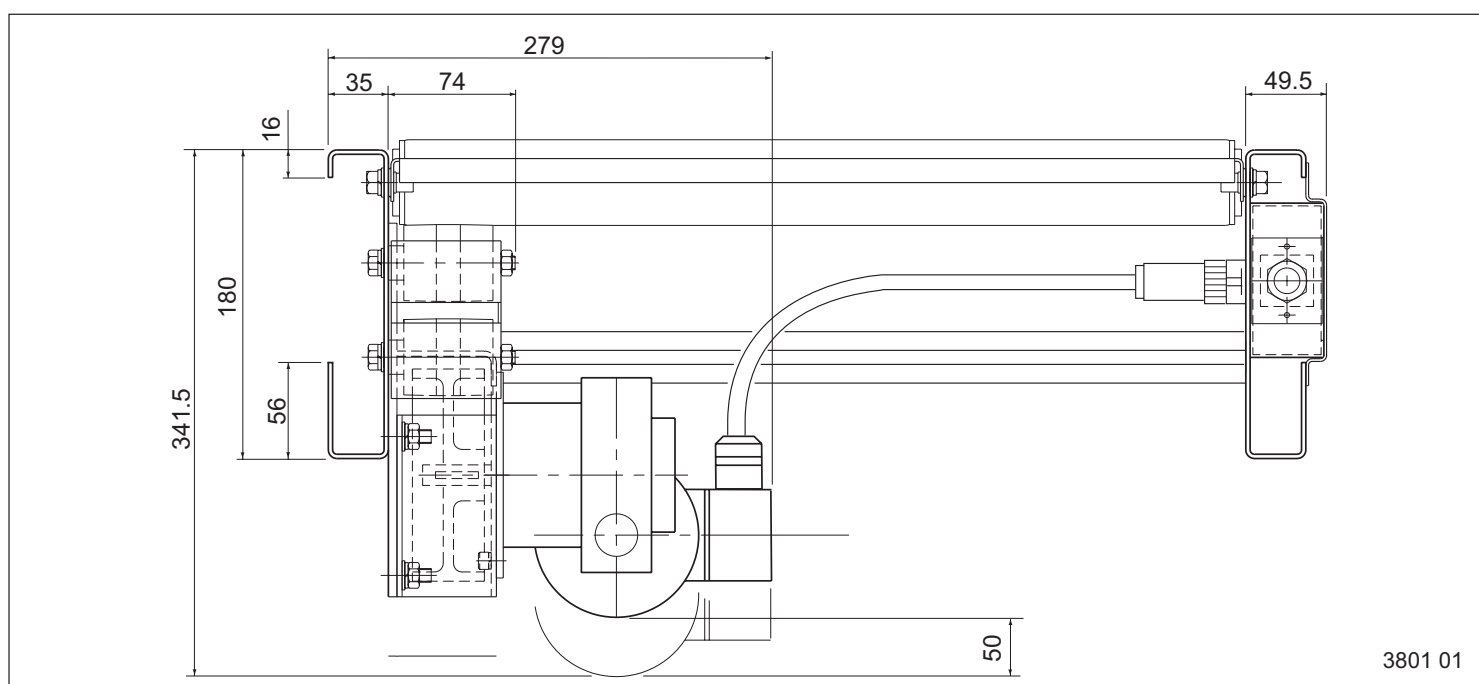

3801 01

## Modular Roller Conveyor System



Modular Roller Curves come pre-fitted with a unique round belt tangential drive system, which acts perpendicular to the roller axes. This provides an efficient, low wearing drive mechanism. As a result, long service life and low maintenance costs are achieved.

- Full range of standard widths available (300 - 800BB).
- Speeds up to 114m/min.
- 30, 45, 60 and 90 degree curves.
- Unique long-life tangential drive belt design
- Quick change drive belt
- Low noise - <65 dBa

# Modular Roller Conveyor System

## Conveyed Loads

Loads must be dry with a smooth base, cardboard or plastic being ideal.

Max product load no greater than 10 kg. per roller.

Max product weight of any single carton is 30 kg.

## Line Pressure

Line pressure is preset at the factory. However raising/ lowering wheel support brackets can adjust line pressure if required.

## Environment

To be used indoors in a dry environment only between 5°C and 40°C ambient temperature.

## Electrical Power

Motors should be connected to 415V 3-phase, 50Hz supply. Curves are supplied pre fitted with a junction box providing a quick plug and socket connection to the motor.

Conveyor Speed	Motor Power (kW)	Running Current (A)
9.8	0.09	0.45
14.0	0.09	0.45
19.0	0.09	0.45
22.0	0.09	0.45
27.0	0.09	0.45
37.0	0.09	0.45
45.6	0.15	0.48
57.0	0.15	0.48
76.0	0.15	0.48
114.0	0.18	0.85

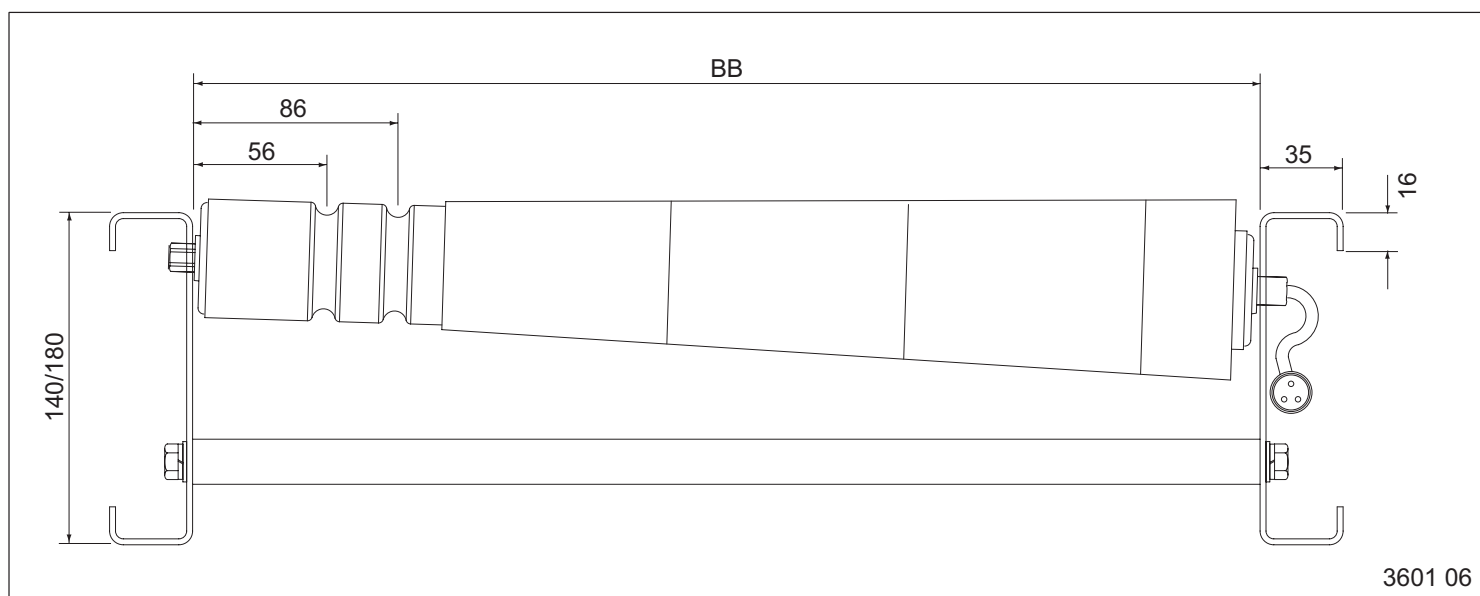

3601 06

## Modular Roller Conveyor System



The personnel gate utilises a unique driver roller system which picks up drive from the adjacent module. Drive is lost when the gate is lifted, and the safe pop out roller design is maintained by a locking device which prevents the rollers from dropping out. Gas struts give assistance during lifting and closing of the gate.

- **Available in all standard widths**
- **Available in 1000mm modules for 805mm clear entry**

# Modular Roller Conveyor System

## Conveyed Loads

Loads must be dry with a smooth base, cardboard on plastic being ideal.

Max product load no greater than 10 kg. per roller.

Max product weight of any single carton is 30 kg.

## Line Pressure

Line pressure is adjustable by repositioning the pressure wheels via the cam adjusters.

## Environment

To be used indoors in a dry environment only between 5°C and 40°C ambient temperature.

## Electrical Power

Personnel gates are slave driven from a preceding bed. No electrical power is required.

## Weight - kg

Conveyor Width (mm)					
300	400	450	500	600	800
39	43	44	46	50	57

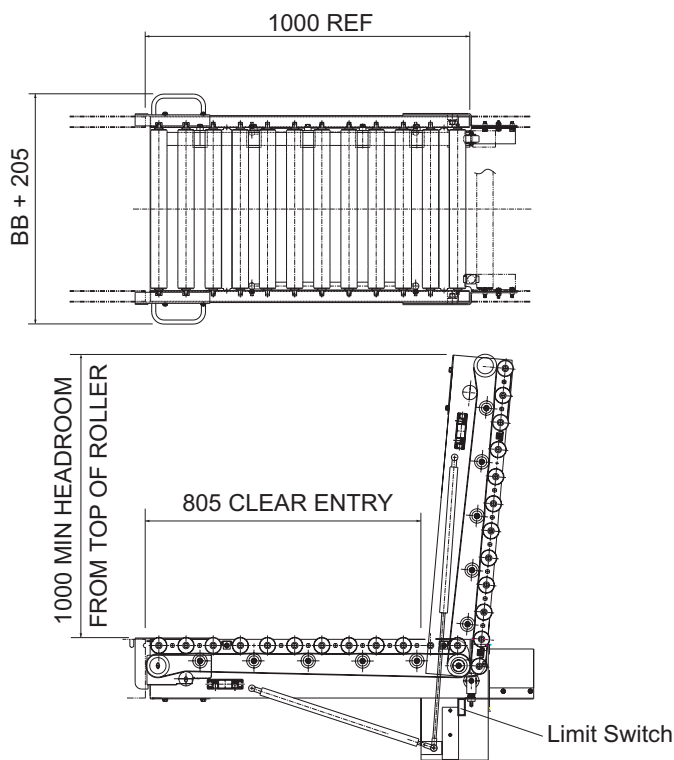

3801 06



## Modular Roller Conveyor System

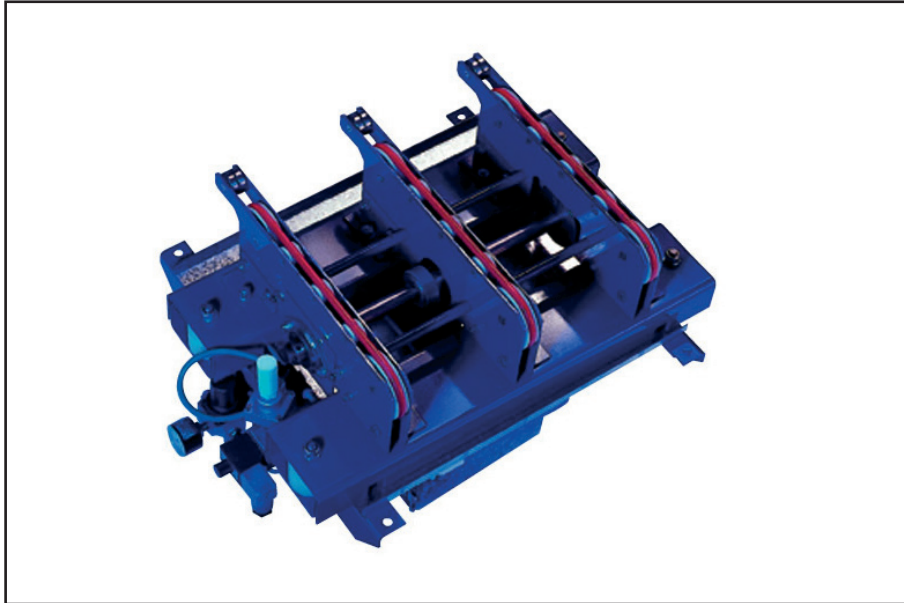

A simple to install self contained unit that can be fitted at any point on a transport straight (in 83mm pitches) to divert packages from, or bring packages onto, a main line. The transfer is fitted with only four bolts, directly to standard pre-drilled holes.

- **Transfer speeds up to 83m/min as standard**
- **Conveyor widths up to 800mm**
- **Supplied with integral pneumatic valve.**
- **Self powered by a 150w motor gearbox meaning the transfer is bi-directional.**



# Modular Roller Conveyor System

## Conveyed Loads

Loads must be dry with a smooth base, cardboard on plastic being ideal.

Max product weight of any single carton is 30 kg.

## Environment

To be used indoors in a dry environment only between 5°C and 40°C ambient temperature.

## Air Supply

To be supplied with dry, unlubricated at 6 bar.

Transfer air consumption = 1.26 litres of free air per operation

## Electrical Power

The transfer is powered from an electrical junction box that can be attached to the side channel of the conveyor the transfer unit is to be fitted into.

Transfer Speed (m/min)	Motor Power (kW)	Running Current (A)
12.6	0.15	0.48
16.6	0.15	0.48
25.2	0.15	0.48
42.1	0.15	0.48
63.0	0.15	0.48

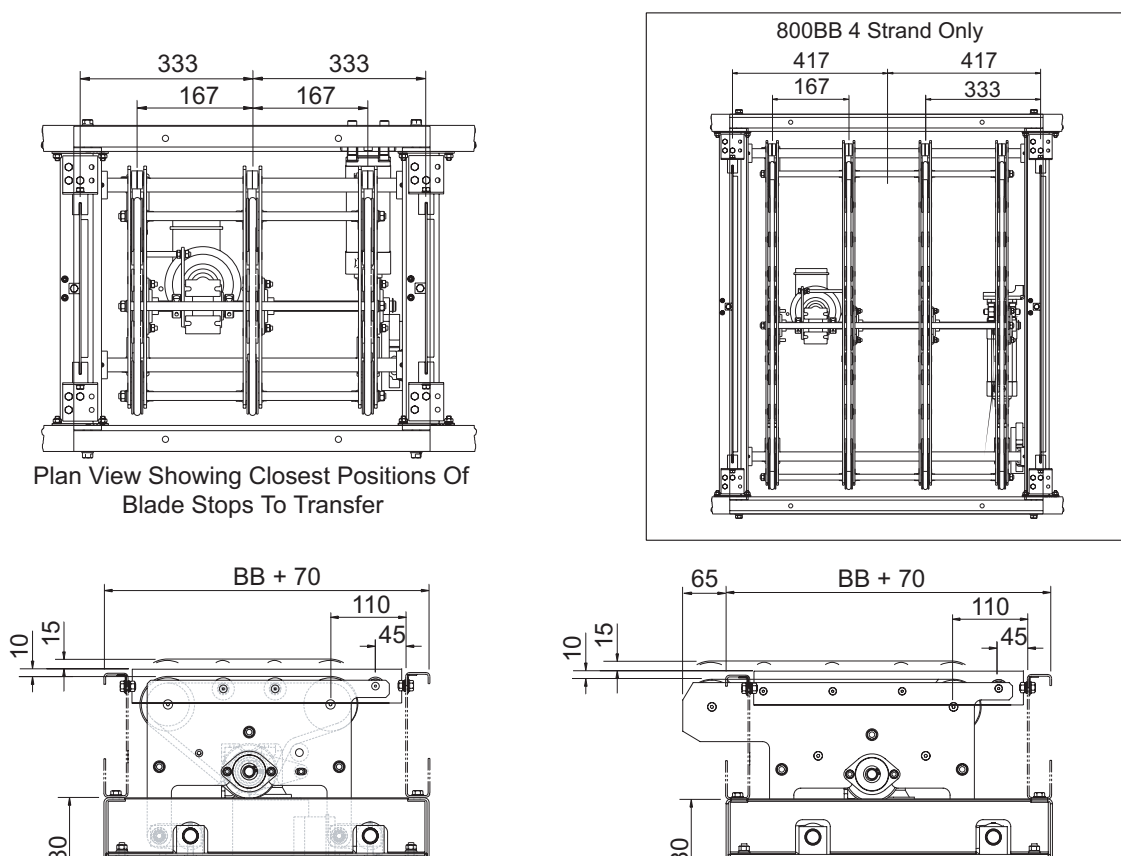

## Modular Roller Conveyor System



The blade stop is used to hold back a queue of boxes and accumulate them. We have designed a speed up roller system that provides a localised speed increase for packages exiting the Blade Stop, enabling a gap to be generated between multiple packages.

- **Full range of widths available**
- **Can be installed at any point on a conveyor**
- **Fast pneumatic operation**

# Modular Roller Conveyor System

## Conveyed Loads

Loads must be dry with a smooth base, cardboard on plastic being ideal.

Max product weight of any single carton is 30 kg.

## Horizontal Force

Must not exceed 290N for conveyor width up to and including 600 BB.

Must not exceed 580N for conveyor widths of 800 BB.

## Air Supply

To be supplied with dry, un lubricated at 6 bar.

## Air Consumption

300 BB to 600 BB: 0.364 Litres of free air per cycle.

800BB: 0.728 litres of free air per cycle.

## Environment

To be used indoors in a dry environment only between 5°C and 40°C ambient temperature.

## Weight - kg

Conveyor Width (mm)					
300	400	450	500	600	800
2.5	3	3.4	3.6	4.2	5.5

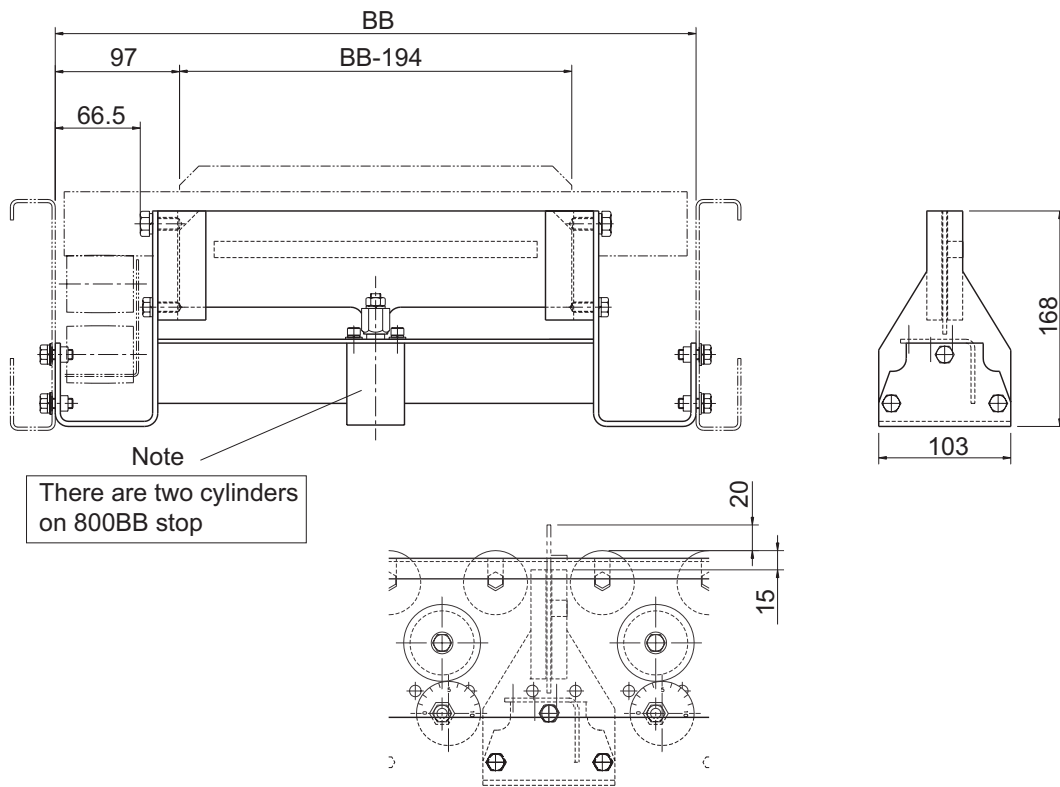

VIEW OF BLADESTOP IN POSITION

3801 08

## Modular Roller Conveyor System



The unique Wallaby design has been added to the Modular Conveyor range from our successful lineshaft system. Used as either single units to perform the function of lane diverters or coupled to other units to form a multi-lane sorter. It is highly suited to the modular concept, so much so that we have been able to increase its speed range (for line and divert rollers). Shorter module lengths give higher discharge lane density in sortation areas, and achieve greater space utilisation.

- **Unique raised tooth divert chain operates to exact package lengths (which means a gap of only 300mm is required between packages)**
- **Throughputs of up to 8,000 packages per hour\* (\*depending on conveyor speed and load properties)**
- **A very cost effective sortation system when used with Cell Controllers**
- **Right and left hand 30 degree modules available**
- **Divert speeds up to 118m/min**
- **Can handle variable package sizes**

# Modular Roller Conveyor System

## Conveyed Loads

Loads must be dry with a smooth base, cardboard on plastic being ideal.

Max product load no greater than 10 kg. per roller.

Max product weight of any single carton is 30 kg.

## Line Pressure

Line pressure is pre-set during manufacture and is not adjustable on this unit.

## Air Supply

To be supplied with dry, unlubricated at 6 bar.

## Air Consumption

0.065 Litres of free air per divert.

## Environment

To be used indoors in a dry environment only between 5°C and 40°C ambient temperature.

## Electrical Power

Motors should be connected to 415V 3-phase, 50Hz supply. Both motors are connected to pre fitted electrical junction boxes by means of plugs and sockets to aid maintenance.

Main Line Speed (m/min)	Motor Power (kW)	Spur Speed (m/min)	Motor Power (kW)
19	0.09	29.5	0.37
22	0.09	29.5	0.37
27	0.09	34	0.37
37	0.09	57.5	0.37
46	0.15	57.5	0.37
37	0.15	71	0.37
76	0.15	88.5	0.37

Right Hand Units						
DIMN Ref	Back to Back Dimension (BB)					
	300	400	450	500	600	800
A	N/A	1500	1500	1500	2000	2250
B	N/A	461	375	288	615	518
C	N/A	778	825	872	965	1151
D	N/A	1819	1806	1794	2269	2468
E	N/A	1476	1563	1650	1823	2169
F	N/A	63	63	63	63	63
G	N/A	975	975	975	1475	1725
H	N/A	537	624	711	884	1230
J	N/A	477	477	477	477	477
*K	100	100	100	100	100	100

Note : Dimension 'K' is the measurement from the end of the motor junction box to the end face of the motor cover.

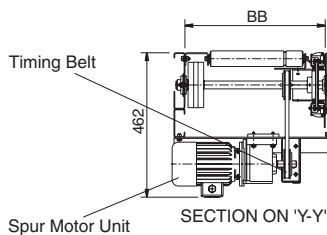
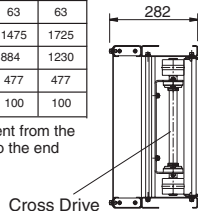

Left Hand Units						
DIMN Ref	Back to Back Dimension (BB)					
	300	400	450	500	600	800
A	N/A	1500	1500	1500	2000	2250
B	N/A	461	375	288	615	518
C	N/A	778	825	872	965	1151
D	N/A	1819	1806	1794	2269	2468
E	N/A	1476	1563	1650	1823	2169
F	N/A	143	143	143	143	143
G	N/A	895	895	895	1395	1645
H	N/A	617	704	791	964	1310
J	N/A	397	397	397	397	397
*K	100	100	100	100	100	100

Note : Dimension 'K' is the measurement from the end of the motor junction box to the end face of the motor cover.

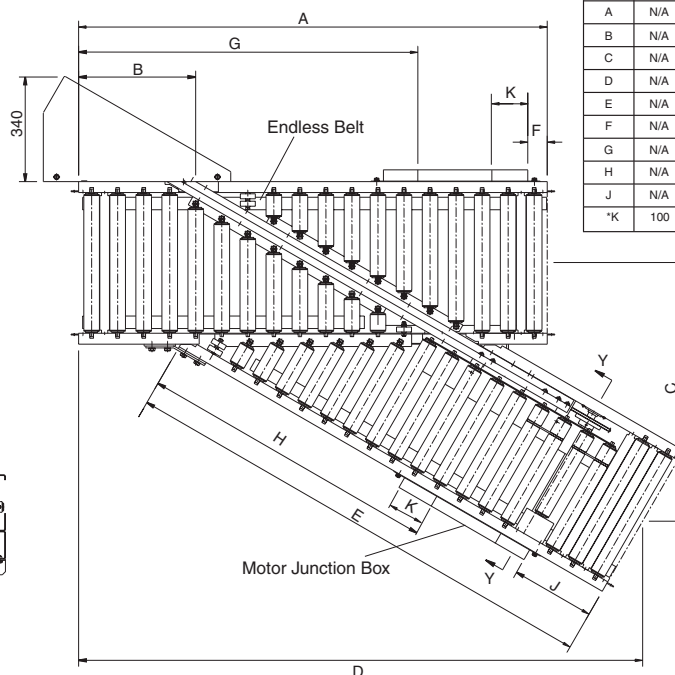

3801 07

## Modular Roller Conveyor System



The unique and highly successful “accumaflow” principle has been applied to the Modular Range of conveyors. This conveyor provides good positive drive yet offers very low pressure as loads accumulate. It features adjustable line pressure and the same efficient and durable flat belt drive system used on transport straights.

- **Modules up to 6m in length**
- **Speeds up to 114m/min**
- **Rollers designed to reduce overall line pressure**
- **83mm roller pitch**
- **Precision bearings used throughout**

# Modular Roller Conveyor System

## Conveyed Loads

Loads must be dry with a smooth base, cardboard on plastic being ideal.

Max product load no greater than 10 kg. per roller.

Max product weight of any single carton is 30 kg.

## Line Pressure

Line pressure is adjustable by repositioning the pressure wheels via the cam adjusters.

## Environment

To be used indoors in a dry environment only between 5°C and 40°C ambient temperature.

## Electrical Power

Motors should be connected to 415V 3-phase, 50Hz supply. Each bed is pre fitted with an electrical junction box providing a plug and socket connection to the motor for ease of maintenance.

Conveyor Speed (m/min)	Module Length (m)	Motor Power (kW)	Running Current (A)
9.8	up to 3	0.09	0.45
9.8	>3 to 6	0.18	0.85
14.0	up to 3	0.09	0.45
14.0	>3 to 6	0.18	0.85
19.0	up to 3	0.09	0.45
19.0	>3 to 6	0.18	0.85
22.0	up to 3	0.09	0.45
22.0	>3 to 6	0.18	0.85
27.0	up to 3	0.09	0.45
27.0	>3 to 6	0.18	0.85
37.0	up to 3	0.09	0.45
37.0	>3 to 6	0.18	0.85
45.6	up to 3	0.15	0.45
45.6	>3 to 6	0.27	0.76
57.0	up to 3	0.15	0.48
57.0	>3 to 6	0.27	0.76
76.0	up to 3	0.15	0.48
76.0	>3 to 6	0.27	0.76
114.0	up to 3	0.18	0.85
114.0	>3 to 6	0.27	0.76

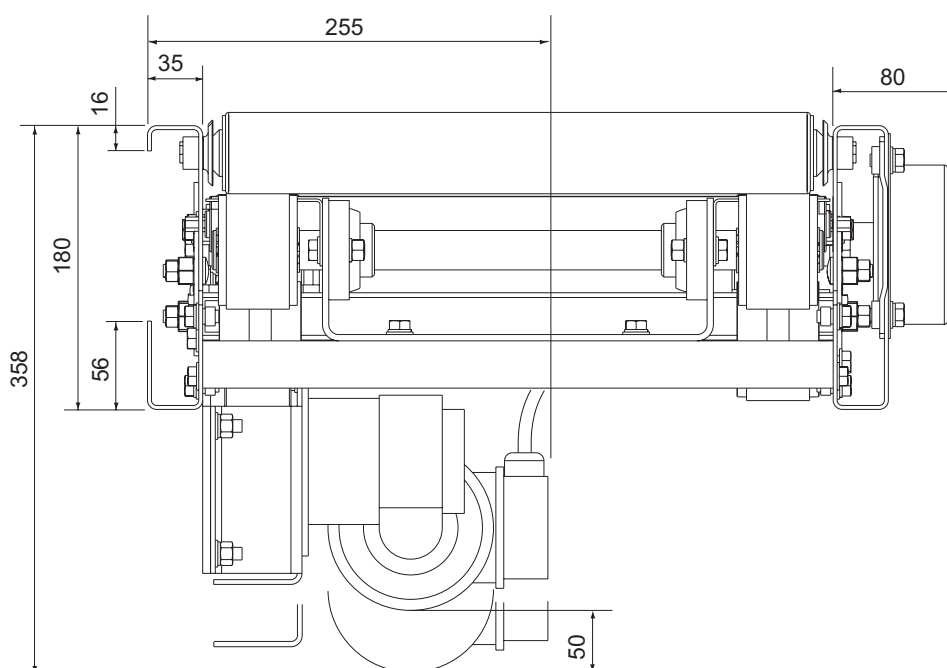

3801 81



## Modular Roller Conveyor System

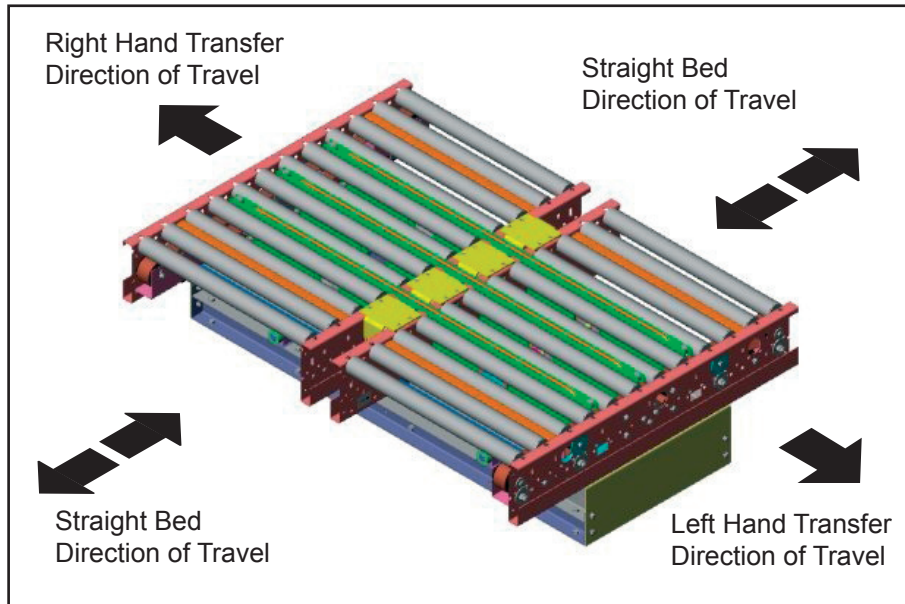

A conveyor module complete with a double transfer unit. The modules are available to suit the standard conveyor widths when there is a 70mm gap between the conveyors.

- **Transfer speeds up to 83m/min as standard.**
- **Conveyor widths up to 800mm.**
- **Bi-directional when controlled via a reversing motor junction box.**
- **83mm roller pitch**
- **Pneumatic operation**
- **Pre-fitted with 24vdc pneumatic solenoid valve.**
- **Up to 30 transfers/minute**

# Modular Roller Conveyor System

## Conveyed Loads

Loads must be dry with a smooth base, cardboard on plastic being ideal.

Max product load no greater than 10 kg. per roller.

Max product weight of any single carton is 30 kg.

## Air Supply

To be supplied with dry, unlubricated at 6 bar.

## Air Consumption

Transfer air consumption = 1.37 litres of free air per operation.

## Environment

To be used indoors in a dry environment only between 5°C and 40°C ambient temperature.

## Electrical Power

Motors should be connected to 415V 3-phase, 50Hz supply.

Transfer Speed (m/min)	Motor Power (kW)	Running Current (A)
14.0	0.06	0.25
17.0	0.06	0.25
28.0	0.06	0.25
42.0	0.06	0.25
55.0	0.06	0.25
83.0	0.06	0.25

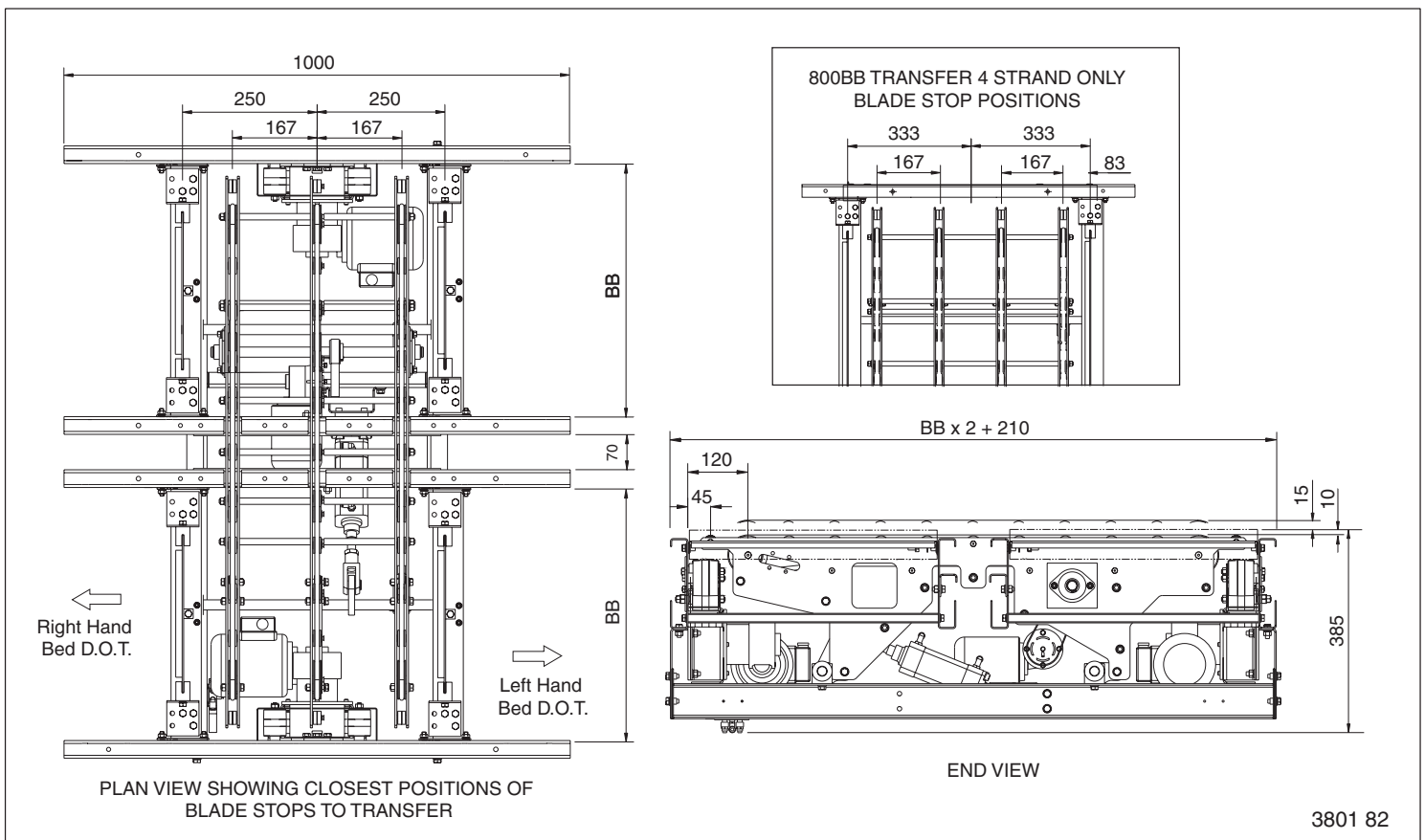

# Modular Roller Conveyor System



MR2 straights are used as a high speed transport conveyor. The conveyor is extremely quiet in operation due to the use of captive rollers.

Long runs of conveyor (up to 30 metres) can be driven by a single drive unit. This provides a very cost effective solution to long runs of conveyor.

- **Drive up to 30 metres in length from a single drive unit**
- **Speeds up to 57m/min**
- **Captive rollers and almost silent running**
- **End terminal assemblies simply bolt in to any conveyor frame**
- **Tension markers on belt enable tension measurement in seconds**
- **40mm wide live roller belt threaded through and joined on site**

# Modular Roller Conveyor System

## Conveyed Loads

Loads must be dry with a smooth base, cardboard or plastic being ideal.

Max product load no greater than 10 kg. per roller.

Max product weight of any single carton is 30 kg.

## Environment

To be used indoors in a dry environment only between 5°C and 40°C ambient temperature.

## Electrical Power

Motors should be connected to 415V 3-phase, 50Hz supply.

Transfer Speed (m/min)	RPM	Power (kW)
9.8	15	0.25
19.0	33	0.37
29.0	46	0.75
37.0	60	0.75
46.0	73	1.1
57.0	93	1.1

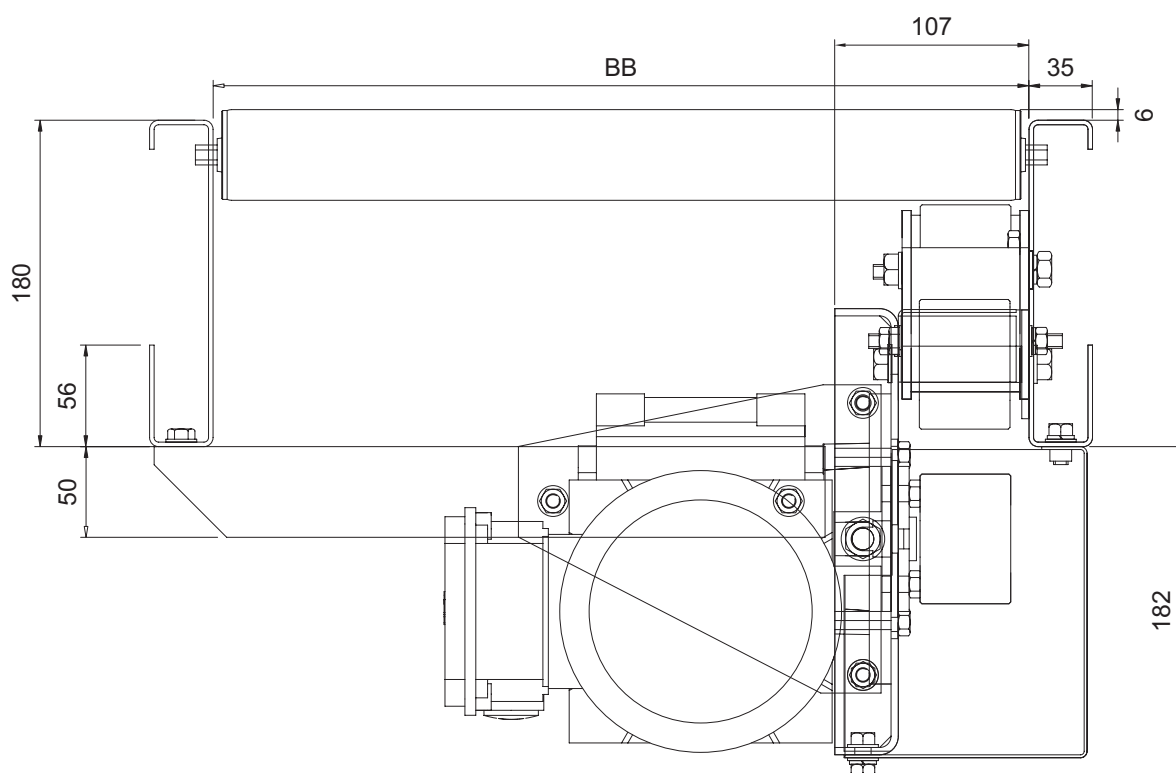

3802 112